

# REAL MOTION

THE FUNCTIONAL COMPANY

[info@real-motion.eu](mailto:info@real-motion.eu)  
[www.real-motion.eu](http://www.real-motion.eu)  
+30 21 0963 1100

2025, Real Motion<sup>®</sup>, all rights reserved

# Solo Dual Adjustable Pully Cable System

# solo.

Utilizing cutting-edge UK design, the Solo Dual Adjustable Pulley Cable System offers the ultimate at-home cable training experience. Its sleek style is matched only by its versatility, allowing for a personalized workout tailored to your fitness level and goals. Get ready to achieve your fitness goals with ease and style.



## Specifications & Dimensions

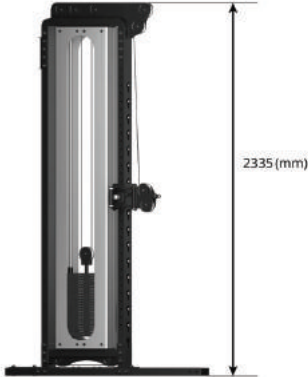
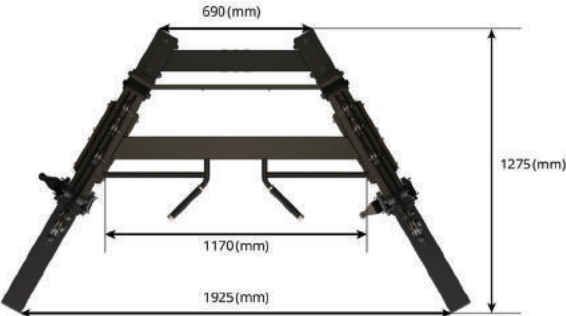

# Solo Half Squat Rack **SOLO.** with Wall Bars, Dip and Leg Raise

This variation on our flagship half squat rack is rammed full of features to help shake up your training. With weight pegs, multiple pull up bar options, wall bars and captain's chair it takes versatility to a new level.

This home power rack has been carefully designed by our team for those serious about training. With its robust 100mm x 50mm (3mm thick) steel construction, it's ready to handle some serious weight lifting.

Since we manufacture each Solo rack to order, we're happy to discuss any bespoke requirements and requests you have for custom sizing and colours.

For those who prefer it, we can offer a multi-grip pull-up alternative to the straight bar that comes as standard. The captain's chair attachment can quickly be removed when not in use so as not to obstruct the rest of the rack's functionality.



## Specifications & Dimensions

Product Weight: 200kg

Dimensions: (h x w x d) 2206mm x 1250mm x 1216mm

Max Loading: 300kg

Material: Mild Steel

J-Hooks: Ultra-high-molecular-weight polyethylene

Steel: 100mm x 50mm Box Section, 3mm Steel Body

# Solo Half Squat Rack with Dual Cable System **SOLO.**

The Solo Half Squat Rack with Dual Cable System is your squat rack and cable machine in one compact setup, built for strength training, functional work, and everything in between.

## Key Features:

- Squat rack and dual cable system in one
- Adjustable cable columns for full-body training
- Built-in storage for plates and accessories
- Premium finish in black, bronze, or silver.

The Solo Half Squat Rack with Dual Cable System combines a high-performance squat rack with a cable pulley system, giving trainers everything they need for strength and functional workouts.

Features a cable pulley system, adding more versatility for strength training beyond squats and presses.



## Specifications & Dimensions

Weight Stacks: 125kg each side

Cable Ratio: 2:1

Dimensions: (h x w x d) 2335mm x 1250mm x 1425mm

Material: Mild Steel



# Solo Half Squat Rack

# solo.

The Solo Half Squat Rack is a heavy-duty, custom-built rack designed for serious training. Made from 100mm x 50mm (3mm thick) steel, it's built for stability and heavy lifting. Each rack is made to order, with options for custom sizing, colors, and a multi-grip pull-up bar upgrade. A modern take on the classic squat rack, it's the perfect centerpiece for any home gym.

The rack comes with a standard straight pull-up bar, but for those who prefer more variety, we offer a multi-grip pull-up option to enhance your upper body training.

Crafted from 100mm x 50mm (3mm thick) steel, this rack is made for heavy lifting and intense workouts. Whether you're squatting, pressing, or pulling, the Solo Half Squat Rack delivers uncompromising stability and strength.

The Solo Half Squat Rack is designed to be the centerpiece of any home gym. We've reimaged the traditional squat rack, moving beyond the industry-standard design to create something bold, modern, and built to last.



## Specifications & Dimensions

Product Weight: 150kg

Dimensions (with weight pegs): (h x w x d) 2240mm x 1764mm x 1405mm

Dimensions (without weight pegs): (h x w x d) 2240mm x 1260mm x 1405mm

Steel: 100mm x 50mm Box Section, 3mm Steel Body

J-Hooks: Ultra-high-molecular-weight polyethylene

Material: Mild Steel



# Signature Storage Bench (Adjustable)

# solo.

The Signature Storage Bench combines luxury design with smart storage, featuring a curved steel frame and built-in space for dumbbells and kettlebells. With a three-position incline backrest and a flat bench alternative, it offers versatility for any workout. Available pre-equipped with weight sets, it's built for durability with a lifetime home warranty on the frame.

## Luxury Design & Smart Storage

Featuring a curved steel frame, this premium storage bench adds a stylish touch to any high-end gym. It provides built-in storage for four pairs of dumbbells and two kettlebells, keeping your workout space organised.



## Specifications & Dimensions

### Additional Specifications

Max Dumbbell Size: 15kg  
Transportation Wheels: Optional  
Pad Thickness: 60mm  
Pad Material: Commercial Grade UPVC Upholstery  
Frame Material: Mild Steel  
Backrest: Three Positions - Flat, Incline, Upright  
Warranty: Lifetime on Steel and Welds, 90 days upholstery

### Dimensions

Length: 995mm  
Width: 390mm  
Height: 449mm  
Weight: 65kg (without weights)





## Adjustable

---

Designed with a three-position incline backrest, this bench enhances your workouts with added functionality. A flat bench alternative is also available for those who prefer a simpler option.

## Warranty Protection

---

Constructed with commercial-grade materials, this bench is designed for durability. It comes with a lifetime home warranty on the steel frame and welds, plus 90 days on upholstery.



## Available colors

---





# solo.

## Solo Wall Mounted Wall Bars

---

It's with simplicity and minimalism in mind we designed the Solo Wall Mounted Wall Bars. We wanted to design a stylish product that wasn't restricted by conventional boundaries and that looks like something we want in our home.

Sometimes known as a Swedish ladder, wall bars are an old-school gym classic. We also supply a dual-function dipping station/leg raise machine which can be mounted onto these (commonly known as a captain's chair.)

This wall-mounted wall bar system has been carefully designed by our team to look amazing in the home.

### Specifications & Dimensions

Weight tbc

Dimensions 2225mm x 1262mm x 510mm

Materials Mild Steel

Steel 100mm x 50mm Box Section, 3mm Steel Body



# solo.

## Solo Wall Mounted Wall Bars with Dip and Leg Raise

---

It's with simplicity and minimalism in mind we designed the Solo Wall Mounted Wall Bars. We wanted to design a stylish product that wasn't restricted by conventional boundaries and that looks like something we want in our home.

Sometimes known as a Swedish ladder, wall bars are an old-school gym classic. With this variation, we have included a dual-function dipping station/leg raise machine which can be mounted onto these (commonly known as a captain's chair.)

This wall-mounted wall bar system with the captain's chair has been carefully designed by our team to look amazing in the home. It features Solo signature commercial-grade upholstery and strong steel construction which comes with our lifetime warranty on welds and steel.

### Specifications & Dimensions

Weight: 100kg

Dimensions: 2225mm x 1262mm x 510mm

Materials: Mild Steel

Steel: 100mm x 50mm Box Section, 3mm Steel Body

# Solo Half Squat Rack with Single Cable Pulley **SOLO.**

The Solo Half Squat Rack with Single Cable Pulley is a premium piece of equipment designed in the UK. With its sleek and stylish aesthetic, it's the perfect addition to any luxury space. The rack connects to a single cable pulley and offers customizable colour options and attachments such as dip, landmine, and spotter arm attachments. Elevate your workout with this versatile and customizable rack.

The Solo Half Squat Rack combines a high-performance squat rack with a cable pulley system, giving trainers everything they need for strength and functional workouts.

With premium j-hooks and optional add-ons like weight storage horns, spotter arms, landmine and dip attachments, this system adapts to your workout goals. Features a cable pulley system, adding more versatility for strength training beyond squats and presses.



## Specifications & Dimensions

Dimensions (height): 2335mm

Dimensions (width): 2430mm

Dimensions (depth): 1400mm

J-Hooks: Ultra-high-molecular-weight polyethylene

Material: Mild Steel



# Solo Training System

# solo.

The Solo Training System is our all-in-one home training hub. It combines a number of our other standalone products in one show-stopping squat rack, storage and bodyweight training combination.

The half squat rack comes with j-hooks and three premium colour options for the front uprights.

Designed and tested by serious athletes, the squat rack is ready to take whatever you can throw its way. We set out to create the most engaging and enjoyable training setup we could imagine for home. That's why we also offer; our (Digital+) model which comes ready to go, with an integrated TV mount and 43" HDTV.

The centre storage unit is available in two lengths (Compact vs Wide) to suit any space and is ready to hold weight plates, dumbbells and other accessories on a flat shelf.

Finally, the second stall bars section has been designed for maximum versatility. It has wall bars, a captains chair (dip bars and leg raise machine) and additional pull up bars.



## Specifications & Dimensions

Dimensions (wide): (h x w) 2240mm x 4315mm

Dimensions (narrow): (h x w) 2240mm x 3220mm

Max Loading: 300kg

Material: Mild Steel

Steel: 80mm x 80mm Box 3mm Wall



# solo.



## Spotter Arms for Solo Squat Racks (Pair)

---

These Spotter Arms for our Solo Squat Racks provide a safe and reliable way to perform squats without assistance at home.

Crafted from durable mild steel, these arms provide peace of mind for solo workouts and are designed to allow for easy exit from squats at the bottom (not for dropping barbells on from a height).

Invest in total control and safety with these Spotter Arms alongside your Solo Rack.

Sold as a pair.

# solo.



## Solo Performance Adjustable Weights Bench

---

This commercial grade weights bench is built to last in high-use environments, ensuring a quality workout experience every time.

It features a stainless steel adjustment plate and knurled handle on the back adjuster, as well as seven incline positions on the backrest and three on the seat pad for maximum versatility.

Elevate your home gym and training with our Solo Performance Adjustable Weights Bench.



# Solo 20kg Olympic Barbell Black Cerakote Solo.

For professional and everyday athletes alike the Olympic barbell is an absolutely essential tool. As people have become more fitness aligned in their lifestyle, confidence in using free weights continues to grow, so where a barbell at home may have been a foreign idea 10 years ago, it certainly isn't any longer.

Quality in an Olympic bar is really important which is why we only supply this commercial quality option. This bar has higher-quality bushings (2) and needle bearings (8), meaning over time the rotation of the sleeves stays smooth. Anyone doing Olympic lifts knows how important this is.

It's also tested to a tensile strength of 190,000 psi, so you can lift in confidence knowing that you'll run out of space on the sleeves before you're in any danger of overloading the bar (rated to 1500lbs).

This barbell features dual IWF and IPF knurl markings, so is without a centre knurl mark that can sometimes be quite harsh when either cleaning, front or back squatting.



## Specifications & Dimensions

Bar Length: 2200mm (7.2ft - Standard Olympic Length)



# solo.



## Olympic Barbell Clamp Collars (Pair)

---

Safety is so important when training with a barbell, especially when you're training on your own at home. Our Olympic Barbell Clamp Collar is designed to quickly and easily secure your barbell, rep after rep.

Especially when training with high volume sets of light weights, plates can slide along the barbell forcing you off balance if they're not secured firmly.

The quick-lock mechanism makes it quick and easy to take collars on and off your barbell. We've chosen a simple black design with a small colour flash on the clasp needed to unlock and secure the collar.



# Olympic Bumper Weight Plates

# solo.

Good quality rubber bumper plates are designed to stand up to the rigours of weight training over long periods of time. They distribute the force of impact when dropped and are suitable to be dropped from overhead (but we'd suggest you only do this on appropriate flooring)...

Traditional bumper plates are colour coded by weight in bright colours, but honestly our preference is all black. Black matches anything and 10 times from 10, will fit much better with the look and feel of a premium home gym. We've even chosen a style with minimal branding so as not to distract from the design of your space.

We have thoroughly tested our bumpers in a variety of high-use commercial gyms, so we're confident in the ability of these plates to withstand the repeated drops of CrossFit and Olympic weightlifting training.

We do include a 5kg plate within this set but advise against dropping it to the ground. Not only is the bounce of the narrowest plate unpredictable, generally a 5kg plate is too narrow to withstand dropping.



## Specifications & Dimensions

The 140kg Set contains: 4 x 20kgs, 4 x 10kgs and 4 x 5kgs

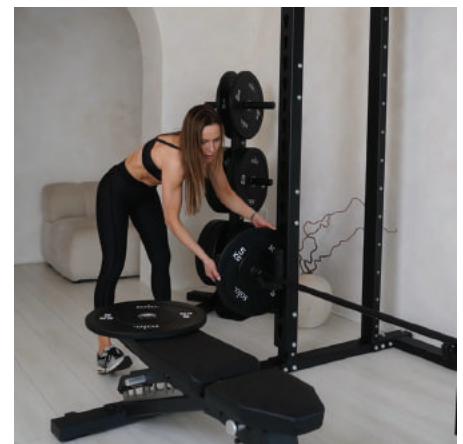

# solo.



## Solo Hex Dumbbells (Rubber)

---

Classic Rubber Hex Dumbbells are the go-to choice for the fitness industry, both for individuals training at home and for commercial gyms. Sometimes a classic design just never needs to be changed.

Hex dumbbells are highly durable, are great to store away due to their flat sides and generally do absolutely everything you need to ask of a dumbbell.

This model has a steel curved handle with knurling and has a weight indicator debossed into the top and bottom of the rubber coating.

For any premium home gym, dumbbells are essential. No matter what the session; HIIT, upper body, lower body, circuits, strength... there's always a place for a few dumbbell movements.



# Premium Rubber Coated Kettlebell (Black) **SOLO.**

Sleek, simple, premium and most importantly; tough.

These premium rubber kettlebells are designed to be used rigorously (as well as to look great). The team at Origin have designed these for use in the busiest of commercial environments where performance is critical, but so is looking great.

The neutral black design hides any marks and blends in with most other equipment. The chrome finish handles add a premium touch, making the kettlebell feel great to use.



## Specifications & Dimensions

Sizes: 4kg, 6kg, 8kg, 10kg, 12kg, 14kg, 16kg, 18kg, 20kg, 22kg, 24kg, 26kg, 28kg



# Classic Medicine Ball (Tan Leather)

---

# solo.

There is just something about a classic leather medicine ball that we think oozes style.

We were so excited when we decided to introduce this to the Solo range. For us, functionality and performance is a priority, but how our products look and feel in the home is also really important.

There are some products we love to train with (like medicine balls), but we have yet to see any designs we love. Strangely, the answer was looking back in time rather than forward! The vintage look leather medicine ball is one of the oldest known pieces of fitness equipment still used today, and its versatility is unrivalled.

Our medicine balls come in 3kg, 6kg and 9kg increments and have a premium tan real leather finish for durability and a luxury feel.

Each medicine ball comes in a tan leather finish and has the weight increment de-bossed on the round end panel.



## Specifications & Dimensions

Sizes: 3kg 6kg 9kg



# solo.



## Art Punchbag - 4ft Tan

---

Built for serious training, the Art 4ft Tan Leather Punchbag offers a timeless look and a solid hitting surface.

Crafted with premium leather and sturdy construction, this bag is your partner for building power, technique, and endurance.

Bag length / height: 120 cm

Bag diameter: 35 cm

Chain length: 55 cm

## Art Boxing Gloves

---

Bring style and performance together with the ART Tan Leather Gloves.

Created for boxers who want a classic look with a modern feel, these gloves deliver comfort, support, and durability for every type of training session, from bag work to sparring.



## Art Boxing Glove Bag

---

Keep your gloves protected and ready to go with the Art Boxing Glove Bag.

Designed to hold gloves up to 14oz, this bag offers a clean, snug fit to keep your gear organised and protected.

# solo.



## Solo Fabric Resistance Band (Set of 3)

---

Enhance your workout with the Solo Fabric Resistance Band Set, featuring three bands in black, grey, and sand, each offering a different resistance level. Designed for durability and comfort, these fabric bands provide effective muscle activation and versatility for strength training, rehabilitation, and mobility exercises.

Ideal for users seeking progressive resistance options in a compact, portable set. The set comes with a black mesh carry bag.





# solo.

## Solo Power Bands - Rubber Exercise Band

---

Used to increase strength, balance, flexibility and mobility. We supply these resistance bands in three colour-coded resistance increments.

All three bands are an equal length. Suitable for adding gradually intensifying resistance to strength training movements. Great for assisted pull ups!

Can be used anywhere combined with bodyweight movements for a comprehensive workout, without the need of lots of kit!

The set comes complete with a lightweight mesh carry bag.

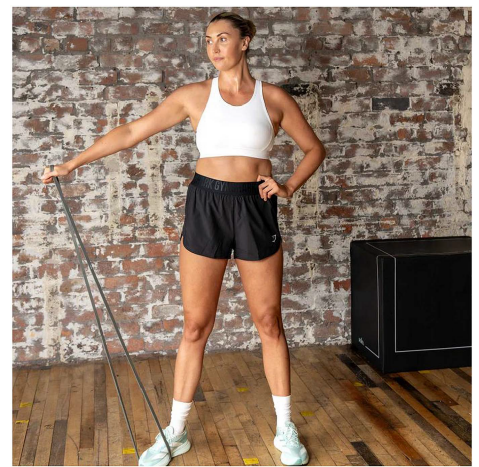
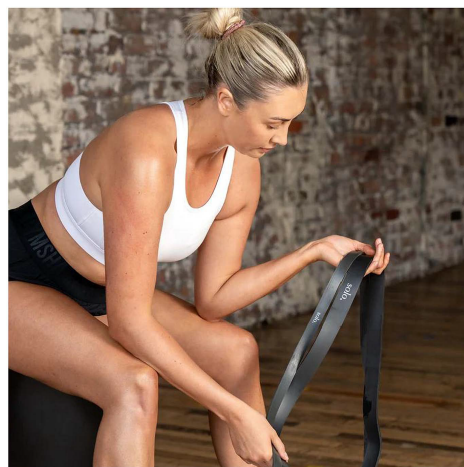
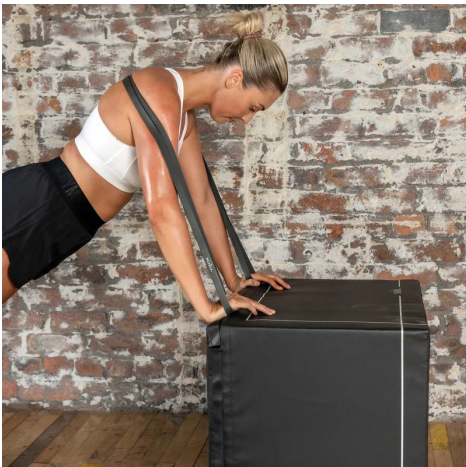



# solo.

## Storage Rack for Yoga Mat or Foam Roller

---

Our wall-mounted yoga mat storage shelf offers the perfect storage rack for your pilates, fitness or yoga mat. It's also an ideal size to act as a foam roller storage shelf. Made from UK steel, this robust storage rack has been designed with our classic black Solo finish to provide a stylish way to organise your home training space.

Foam Rollers and Yoga Mats, Fitness Mats or Pilates Mats are often the final few accessories in the home gym without a clear storage location. Their awkward shape means you regularly see them stuffed in a corner or just left sitting on their end. In creating meaningfully designed home gym spaces we understand that everything should have its place and dedicated storage helps keep your training space (and your mind) clear.

The durable design utilises a single sheet of 2mm mild steel. At just 196mm x 500mm, the storage channel has been designed to offer storage for oversized fitness mats and thick mats as well as standard sized yoga mats.

We provide appropriate wall fixings with this product but do recommend if you are unsure about wall mounting any products, you seek professional assistance. We recommend fixing these to a solid structural wall only.

### Specifications & Dimensions

Total dimensions: 500mm x 250mm x 196mm

Colour: Black

Material: Steel

Wall Fixings: Included

Storage for: Yoga Mats, Fitness Mats, Exercise Mat,  
Stretch Mats, Pilates Mats, Foam Rollers



# solo.



## Gym Hanger for Resistance Bands, Belts and Ropes

---

Our multi-purpose gym accessory hanger is the ideal storage solution for resistance bands, weightlifting belts and skipping ropes. It comes with eight storage prongs and four wall mounting holes for secure fixing.

We always say a stylish gym is an organised gym. Each item should have its place in the gym; otherwise, clutter is hard to avoid. Clutter kills style.

Our eight pronged storage hanger has the capacity to store various sizes of resistance bands, plus a couple of weightlifting belts and skipping ropes. There's no better way to organise your accessories.

Hangers for skipping ropes and resistance bands is actually the best way you keep them in great condition. Some bands and ropes can hold their shape when they're wrapped up tightly, resulting in annoying wrinkles that take a while to straighten out. This item is made from 3mm thick steel, so describing it as durable doesn't do it justice. It's also finished with our grippy and textured Dakota Black paint finish.

We provide appropriate wall fixings with this product but do recommend if you are unsure about wall mounting any products, you seek professional assistance. We recommend fixing these to a solid structural wall only.

### Specifications & Dimensions

Width: 420mm

Depth: 119mm

Prong Size: 27mm

Distance Between Prongs: 30mm

Fixings: Included



# solo.

## Vertical Wall Mounted Barbell Hanger (Single Bar)

---

A stylish gym is an organised gym. The coolest home training spaces are those that are well planned and deliberately thought out.

The most effective, space-saving way to store a barbell is against the wall. It maximises the training floor space available, keeps the bar within easy reach but neatly stored at the same time.

Storing your barbell on the floor 'out-of-the-way' is fine... until you've stubbed a toe on it. We've all done it.

Our barbell hanger is simple and solid. The minimal design aims to complement most other equipment styles, so we've gone with a textured matt black finish.

Made of a single piece of 5mm steel for maximum integrity over time.

It features 12mm diameter holes for you to securely fix the hanger to a solid wall in the gym.

Suitable for use with any standard sized Olympic barbells. Distance between the prongs is 35mm.



### Specifications & Dimensions

Width: 365mm

Depth: 120mm

Prong Size: 65mm

Distance Between Prongs: 35mm

Fixings: Included

# solo.



## Vertical Wall Mounted Barbell Hanger (3 Bars)

---

We always say a stylish gym is an organised gym. Each item should have its place in the gym otherwise clutter is hard to avoid. Clutter kills style.

Our Vertical Wall Mounted Barbell Hanger is the perfect storage accessory to keep your gym space organised. Storing your barbell in the power rack is, fine. But it limits the ability to use it for pull-ups and kills the space inside the rack when not in use. Storing your barbell collection against the wall is the most effective solution in almost all scenarios.

Our hanger is simple and solid. The minimal design aims to fit the colour scheme of any space and is made of a single piece of 5mm steel. It features 12mm diameter holes for you to securely fix the hanger to a solid wall in the gym.

We provide appropriate wall fixings with this product but do recommend if you are unsure about wall mounting any products, you seek professional assistance. We recommend fixing these to a solid structural wall only.



### Specifications & Dimensions

Width - 165mm

Height - 80mm

Depth - 120mm

Fixings: Included

# solo.



## Solo Gym Kit Hangers

---

Our goal is to make home gym spaces beautiful, one at a time. Part of this mission is reducing clutter and making sure everything has a home within your training space.

This Solo Gym Kit Hanger has been a key feature in many of our garage gym projects and gym spaces in garden rooms. In the British winter-time, hoodies are essential - at the very least while you get warmed-up.

This multi-use kit hanger is perfect for coats, hoodies and hats while you train - but is also a great option for storing some of your light accessories like bands, ropes and belts.

We offer this product in a four hook or single hook version, both made from super strong 3mm mild steel.



## Specifications & Dimensions

Single Hook

Dimensions: 75mm x 70mm x 38mm

Four Hook

Dimensions: 550mm x 70mm x 38mm

# solo.

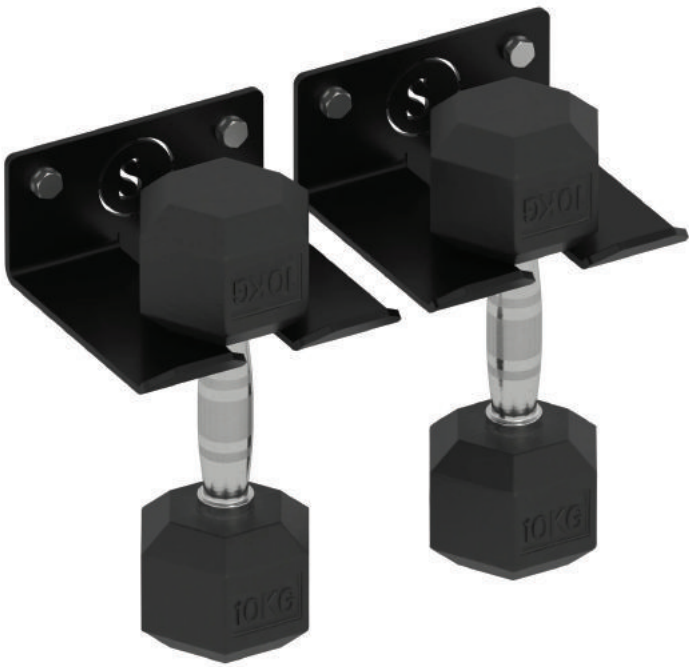

## Wall Mounted Dumbbell Storage Hook (Single Dumbbell)

---

This wall-mounted dumbbell storage hook is specifically designed to keep your gym neat and organized. Its mild steel construction can securely hold a single dumbbell when appropriately fixed to a solid wall.

We want this product to ensure your training space is sleek, stylish and is always ready for your next workout. These are sold as single hooks, so to store a pair of dumbbells, please make sure you order two! These options are designed with Solo Hex Dumbbells in mind and are suitable for weights up to 30kg.

They will work for dumbbells of other sizes, but please ensure you check the dimensions below before ordering.

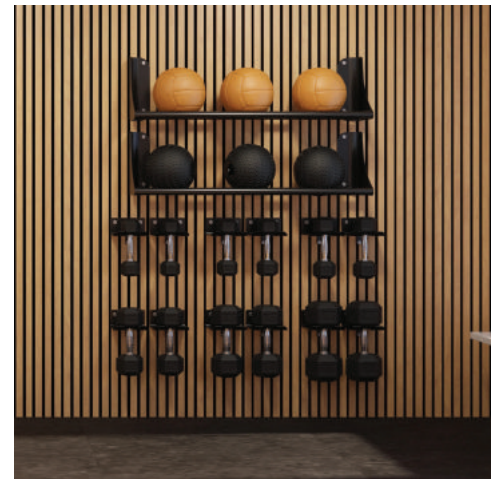

### Specifications & Dimensions

Horizontal Hook

Minimum handle length = 115mm

Max head diameter (across flat sides if hex) = 210mm

Vertical Hook

Max head diameter (across flat sides if hex) = 165mmz

# solo.

## Wall Mounted Weight Plate Storage Pegs (3 Pegs)

---

Optimise your training space with the Solo wall-mounted weight plate storage pegs. Often space is at a premium in even the best home gyms, so wall-mounted storage is a great space-saving strategy. Weight plate storage can sometimes be challenging because traditional weight plate racks take up a lot of floor space.

If you're looking for a clean and simple solution to store weight plates or bumper plates, look no further. Our wall-mounted weight storage pegs is a great solution.

There generally isn't built-in storage for gyms where you've chosen either a wall-mounted rack or squat stands, so wall-mounted weight plate pegs are an ideal option.

This set of pegs comes connected as a set of three, with one long backplate and three pegs. The backplate ensures the pegs are evenly spaced, and reduces the overall number of wall mounting holes you'll need to install. Each item is finished with our matte black commercial powder coat.



### Specifications & Dimensions

The storage capacity of each peg depends largely on the width of the plates being used with it, but the peg length itself is 250mm.



# solo.

## Solo Weight Plate Storage Tree

---

This item is made-to-order, so has a 2-3 week lead time

This Solo Weight Plate Storage Tree is the perfect freestanding solution for keeping the free weights space in your gym organised. The strong mild steel construction and commercial powder-coated finish in matt black offers durability over time.

The rack is designed to hold standard olympic sized weight discs and bumper weight plates.

Quickly put plates on and off the weight horns, and keep your gym space clear and tidy.

Weight Plates pictured are not included but can be found [here](#).



### Specifications & Dimensions

Height 1458mm

Depth 600mm

Width 716mm

# solo.



## Wall Mounted Medicine Ball Halo

---

Designed to hold single medicine balls on each mount, this wall mounted storage solution is perfect for any gym or fitness center.

Keep your space organized and your workout equipment easily accessible with this innovative product.

Suitable for medicine balls of up to 14" diameter.



## Wall Mounted Medicine Ball Storage Rail

---

Organize and store your wall balls and medicine balls with our elegant Wall Mounted Medicine Ball Storage Rail.

- 3 x medicine balls or wall balls with 12-inch diameter
- 4 x medicine balls or wall balls with 10-inch diameter
- 5 x medicine balls or wall balls with 8-inch diameter

Overall dimensions are 1086mm x 265mm x 300mm, and the unit requires four wall fixings.



# solo.



## Solo Vault Weights Storage Rack - Small

Keeping your home gym space organised has never been easier than with our new narrower version of our classic Solo Vault Storage Rack.

Smart weights racks have always been a great way to make your garage gym look amazing, with this one, we've tried to fuse our unique Solo design with a compact and functional rack.

With this new smaller size, our weights stand doesn't consume too much valuable floor space. By combining a medicine ball rail, a dumbbell shelf and a flat kettlebell shelf, we've tried to maximise the number of items you can store in here.



### Specifications & Dimensions

Overall dimensions of this unit are: 1000mm (H) x 670mm (W) 450mm (D)

# solo.



## Solo Vault Home Weights Storage Rack

---

Keeping your home gym space organised has never been easier than with our new Home Weights Storage Rack.

Smart weights racks have always been a great way to make your garage gym look amazing, with this one, we've tried to fuse our unique Solo design with a compact and functional rack.

With a compact size, our weights stand doesn't eat up too much valuable floor space. By combining a dumbbell rack and a flat kettlebell shelf we've tried to maximise the number of items you can store in here.



### Specifications & Dimensions

Product Weight: 100kg

Dimensions (h x w x d): 1000mm x 1110mm x 504mm

Material: Mild Steel

Steel: 3mm Steel Body

FREEMOTION.



solo.



POWERED BY  
**REAL MOTION**  
THE FUNCTIONAL COMPANY

